

SERPAC 033

Electronics Enclosures

NOTES:
1. WHEN MACHINE OR PLATES MODIFICATIONS ARE REQUIRED, USE THE CENTER OF THE BOX TO DIMENSION.

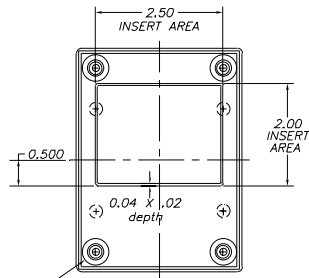
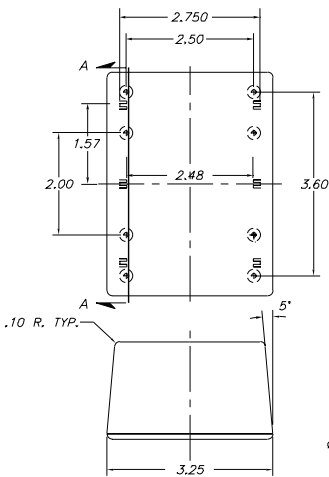
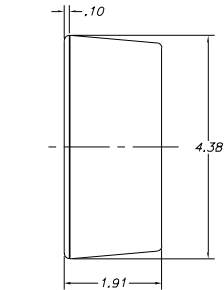

Ø.52 X .005 FOR FEET

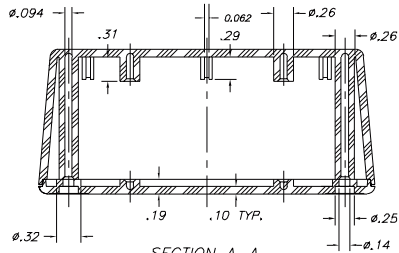
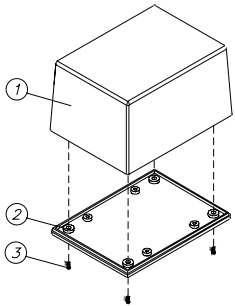

SECTION A-A

8-17-98. ALL DIMENSIONS ± .010

ITEM	PART NO.	DESCRIPTION	ACCESSORIES	
1	33	PLASTIC TOP	PART NO.	DESCRIPTION
2	03	PLASTIC BOTTOM	51	FEET
3	6005	SCREWS (4)	330	PROTOTYPE GRID BOARD (HORIZ.)
			430	PROTOTYPE CLAD BOARD (HORIZ.)